



Previous Year Question Paper  
of

**CSIR – UGC JRF / NET**  
**LIFE SCIENCES**  
**Examination**

**DECEMBER 2011 (II)**

*(Original Question Paper with Answer Key)*  
COUNCIL OF SCIENTIFIC & INDUSTRIAL RESEARCH



For more question papers, please visit: [www.easybiologyclass.com](http://www.easybiologyclass.com)



2011 (II)  
LIFE SCIENCES  
TEST BOOKLET



Time : 3:00 Hours

Maximum Marks : 200

**INSTRUCTIONS**

1. **You have opted for English as medium of Question Paper.** This Test Booklet contains one hundred and forty five (20 Part 'A'+50 Part 'B' +75 Part 'C') Multiple Choice Questions (MCQs). You are required to answer a maximum of 15, 35 and 25 questions from part 'A' 'B' and 'C' respectively. If more than required number of questions are answered, only first 15, 35 and 25 questions in Parts 'A' 'B' and 'C' respectively, will be taken up for evaluation.
2. Answer sheet has been provided separately. Before you start filling up your particulars, please ensure that the booklet contains requisite number of pages and that these are not torn or mutilated. If it is so, you may request the Invigilator to change the booklet. Likewise, check the answer sheet also. Sheets for rough work have been appended to the test booklet.
3. Write your Roll No., Name, your address and Serial Number of this Test Booklet on the Answer sheet in the space provided on the side 1 of Answer sheet. Also put your signatures in the space identified.
4. **You must darken the appropriate circles with a pencil related to Roll Number, Subject Code, Booklet Code and Centre Code on the OMR answer sheet. It is the sole responsibility of the candidate to meticulously follow the instructions given on the Answer Sheet, failing which, the computer shall not be able to decipher the correct details which may ultimately result in loss, including rejection of the OMR answer sheet.**
5. Each question in Part 'A' and 'B' carries 2 marks and Part 'C' questions carry 4 marks each respectively. There will be negative marking @ 25% for each wrong answer.
6. Below each question in Part 'A', 'B' and 'C' four alternatives or responses are given. Only one of these alternatives is the "correct" option to the question. You have to find, for each question, the correct or the best answer.
7. **Candidates found copying or resorting to any unfair means are liable to be disqualified from this and future examinations.**
8. Candidate should not write anything anywhere except on answer sheet or sheets for rough work.
9. After the test is over, you MUST hand over the answer sheet (OMR) to the invigilator
10. Use of calculator is not permitted.

Roll No. 325809.....

Name ATUL KUMAR GOYAL

I have verified all the information filled in by the candidate.

*Dish*  
Signature of the Invigilator

## PART A

1. What is the angle  $\theta$  in the quadrant of a circle shown below?

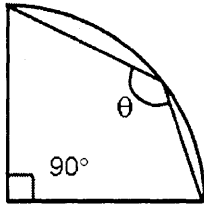

1.  $135^\circ$
2.  $90^\circ$
3.  $120^\circ$
4. May have any value between  $90^\circ$  and  $120^\circ$

**Ans. 1**

2. In  $\triangle ABC$ , angle A is larger than angle C and smaller than angle B by the same amount. If angle B is  $67^\circ$ , angle C is

- |                |                |
|----------------|----------------|
| (1) $67^\circ$ | (2) $53^\circ$ |
| (3) $60^\circ$ | (4) $57^\circ$ |

**Ans. 2**

3. See the following mathematical manipulations.

- (i) Let  $x = 5$
- (ii) then  $x^2 - 25 = x - 5$
- (iii)  $(x - 5)(x + 5) = x - 5$
- (iv)  $x + 5 = 1$  [cancelling  $(x - 5)$  from both sides]
- (v)  $10 = 1$  [Putting  $x = 5$ ]

Which of the above is the wrong step?

- |                   |                   |
|-------------------|-------------------|
| (1) (i) to (ii)   | (2) (ii) to (iii) |
| (3) (iii) to (iv) | (4) (iv) to (v)   |

**Ans. 4**

4. Inner planets of the solar system are rocky, whereas outer planets are gaseous. One of the reasons for this is that

1. solar heat drove away the gases to the outer region of the solar system
2. gravitational pull of the sun pulled all rocky material to the inner solar system
3. outer planets are larger than the inner planets
4. comets delivered the gaseous materials to the outer planets

**Ans. 1**

5. The number of craters observed due to meteoritic impacts during the early stages of formation, is less on the Earth than that on the Moon because,

1. formation of craters on the Earth was difficult due to the presence of hard rocks
2. impacting bodies on the Earth were smaller in size
3. craters on the Earth are now covered by ocean water
4. earlier craters are not preserved due to continuous modification of Earth's surface by geological processes

**Ans. 4**

6. During a total solar eclipse occurring at noon, it becomes dark enough for a few minutes for stars to become visible. The stars that are seen are those which will be seen from the same location

1. on the following night only
2. on the night one month later
3. on the night three months later
4. on the night six months later

**Ans. 3**

7. The variation of solubilities of two compounds X and Y in water with temperature is depicted below. Which of the following statements is true?

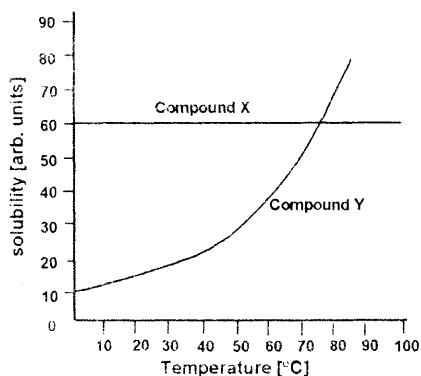

1. Solubility of Y is less than that of X
2. Solubility of X varies with temperature
3. Solubilities of X and Y are the same at 75°C
4. Solubilities of X and Y are independent of temperature

**Ans. 3**

8. Living beings get energy from food through the process of aerobic respiration. One of the reactants is

- (1) carbon dioxide
- (2) water vapour
- (3) oxygen
- (4) phosphorus

**Ans. 3**

9. Restriction endonuclease cleaves DNA molecules at specific 'recognition sites'. One such enzyme has four recognition sites on a circular DNA molecule. After complete digestion, how many fragments would be produced upon reaction with this enzyme?

- (1) 4
- (2) 5
- (3) 3
- (4) 6

**Ans. 1**

10. Which of the following statements about the concentration of CO<sub>2</sub> in the Earth's atmosphere is true?

1. It was the highest in the very early atmosphere of the Earth
2. It has steadily decreased since the formation of the Earth's atmosphere
3. It has steadily increased since the formation of the Earth's atmosphere
4. Its levels today are the highest in the Earth's history

**Ans. 2**

11. Magnesium powder, placed in an airtight glass container at 1.0 bar, is burnt by focusing sunlight. Part of the magnesium burns off, and some is left behind. The pressure of the air in the container after it has returned to room temperature is approximately

- (1) 1.0 bar
- (2) 0.2 bar
- (3) 1.2 bar
- (4) 0.8 bar

**Ans. 4**

12. When a magnet is made to fall free in air, it falls with an acceleration of 9.8 m s<sup>-2</sup>. But when it is made to fall through a long aluminium cylinder, its acceleration decreases, because

1. a part of the gravitational potential energy is lost in heating the magnet
2. a part of the gravitational potential energy is lost in heating the cylinder
3. the said experiment was done in the magnetic northern hemisphere
4. the cylinder shields the gravitational force

**Ans. 1**

13. A solid cube of side  $L$  floats on water with 20% of its volume under water. Cubes identical to it are piled one-by-one on it. Assume that the cubes do not slip or topple, and the contact between their surfaces is perfect. How many cubes are required to submerge one cube completely?

- (1) 4
- (2) 5
- (3) 6
- (4) Infinite

**Ans. 2**

14. An overweight person runs 4 km everyday as an exercise. After losing 20% of his body weight, if he has to run the same distance in the same time, the energy expenditure would be

1. 20% more
2. the same as earlier
3. 20% less
4. 40% less

Ans. 3

15. On exposure to desiccation, which of the following bacteria are least likely to experience rapid water loss?

1. Isolated rods
2. Rods in chain
3. Cocci in chain
4. Cocci in clusters

Ans. 4

16. A cupboard is filled with a large number of balls of 6 different colours. You already have one ball of each colour. If you are blind-folded, how many balls do you need to draw to be sure of having 3 colour-matched pairs of balls?

- |       |       |
|-------|-------|
| (1) 3 | (2) 4 |
| (3) 5 | (4) 6 |

Ans. 4

17. The conductance of a potassium chloride solution is measured using the arrangement depicted below. The specific conductivity of the solution in  $\text{Sm}^{-1}$ , when there is no deflection in the galvanometer, is

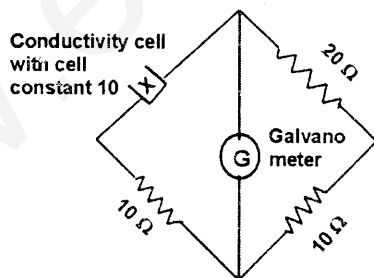

- |         |         |
|---------|---------|
| (1) 1.0 | (2) 0.5 |
| (3) 2.0 | (4) 1.5 |

Ans. 2

18. What is the half-life of the radio isotope whose activity profile is shown below?

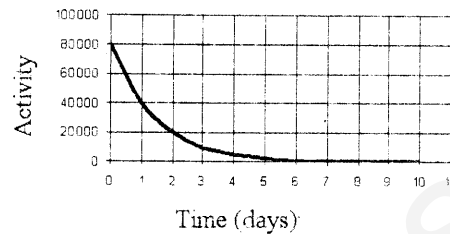

- |            |            |
|------------|------------|
| (1) 1 day  | (2) 3 days |
| (3) 2 days | (4) 4 days |

Ans. 1

19. A bell is rung before giving food to a dog. After doing this continuously for 10 days, which of the following is most likely to happen?

1. The dog learns to ignore the bell
2. The dog salivates on hearing the bell
3. The dog ignores food and runs towards the bell
4. The dog will not eat food without hearing the bell

Ans. 2

20. For an elastic material, strain is proportional to stress. A constant stress is applied at time  $t_1$ . Which of the following plots characterizes the strain in that material?

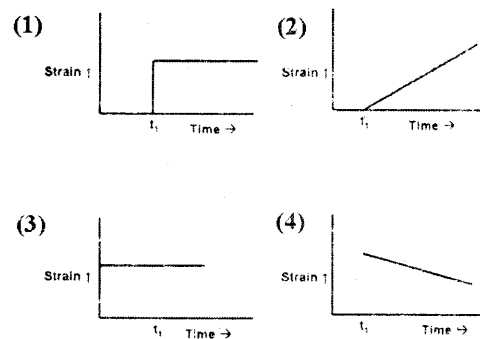

Ans. 1

**PART B**

21. On the molar scale which of the following interactions in a nonpolar environment provides highest contribution to the bio-molecule?

1. van der Waals interaction
2. Hydrogen bonding
3. Salt bridge
4. Hydrophobic interaction

*Ans. 1*

22. Michaelis and Menten derived their equation using which of the following assumption?

1. Rate limiting step in the reaction is the breakdown of ES complex to product and free enzyme
2. Rate limiting step in the reaction is the formation of ES complex
3. Concentration of the substrate can be ignored
4. Non-enzymatic degradation of the substrate is the major step

*Ans. 1*

23. In which form of DNA, the number of base pairs per helical turn is 10.5?

- (1) A                      (2) B  
(3) X                      (4) Z

*Ans. 2*

24. In contrast with plant cells, the most distinctive feature of cell division in animal cells is

1. control of cell cycle transitions by protein kinases
2. enzymes responsible for DNA replication
3. ubiquitin-dependent pathway for protein degradation
4. pattern of chromosome movement

*Ans. 4*

25. Most common type of phospholipids in the cell membrane of nerve cells is

1. phosphatidylcholine
2. phosphatidylinositol
3. phosphatidylserine
4. sphingomyelin

*Ans. 1*

26. Reverse transcriptase has both ribonuclease and polymerase activities. Ribonuclease activity is required for

1. the synthesis of new RNA strand
2. the degradation of RNA strand
3. the synthesis of new DNA strand
4. the degradation of DNA strand

*Ans. 2*

27. The membrane lipid molecules assemble spontaneously into bilayers when placed in water and form a closed spherical structure known as

- (1) lysosome      (2) peroxisome  
(3) liposome      (4) endosome

*Ans. 3*

28. In gene regulation, Open Reading Frame (ORF) implies

1. intervening nucleotide sequence in between two genes
2. a series of triplet codons not interrupted by a stop codon
3. a series of triplet codons that begins with a start codon and ends with a stop codon
4. the exonic sequence of a gene that corresponds to the 5'UTR of the mRNA and thus does not code for the protein

*Ans. 3*

29. Amino acid selenocysteine (Sec) is incorporated into polypeptide chain during translation by

1. charging of Sec into tRNA<sup>ser</sup> followed by incorporation through serine codon
2. charging of serine into tRNA<sup>ser</sup> followed by modification of serine into selenocysteine and then incorporation through serine codon
3. charging of Sec into tRNA<sup>sec</sup> and then incorporation through selenocysteine codon
4. charging of serine into tRNA<sup>ser</sup>, modification of serine into selenocysteine and then incorporation through a specially placed stop codon

*Ans. 4*

30.  $\alpha$ -amanitin inhibits
1. only RNA polymerase I
  2. only RNA polymerase II
  3. only RNA polymerase III
  4. all RNA polymerases **Ans. 2**
31. While replicating DNA, the rate of misincorporation by DNA polymerase is 1 in  $10^5$  nucleotides. However, the actual error rate in the replicated DNA is 1 in  $10^9$  nucleotides incorporated. This is achieved mainly due to
1. spontaneous excision of misincorporated nucleotides
  2. 3'→5' proof reading activity of DNA polymerase
  3. termination of DNA polymerase at misincorporated sites
  4. 5' →3' proof reading activity **Ans. 2**
32. Toxic shock is caused by
1. toxins produced by some bacteria
  2. excessive stimulation of a large proportion of T cells by bacterial superantigens
  3. abnormal cytokine production by B cells
  4. excessive production of immunoglobulins **Ans. 2**
33. Ethylene binding to its receptor, does NOT lead to
1. dimerization of the receptor
  2. phosphorylation of the receptor
  3. activation of CTR Raf kinase
  4. endocytosis of ethylene-receptor complex **Ans. 4**
34. Graft rejection does not involve
1. erythrocytes
  2. T cells
  3. macrophages
  4. polymorphonuclear leukocytes **Ans. 1**
35. The blastopore region of amphibian embryo that secretes BMP inhibitors and dorsalizes the surrounding tissue is known as
1. Brachet's cleft
  2. Nieuwkoop center
  3. Spemann's organizer **Ans. 3**
  4. Hensen's node
36. During development of embryos in plants, PIN proteins are involved in
1. establishment of auxin gradients
  2. regulation of gene expression
  3. induction of programmed cell death
  4. induction of cell division **Ans. 1**
37. Which of the following maternal effect gene products regulate production of anterior structures in *Drosophila* embryo?
1. Bicoid and Nanos
  2. Bicoid and Hunchback
  3. Bicoid and Caudal
  4. Nanos and Caudal **Ans. 2**
38. Which of the floral whorls is affected in *agamous* (*ag*) mutants?
1. Sepals and petals
  2. Petals and stamens
  3. Stamens and carpels
  4. Sepals and carpels **Ans. 3**
39. Which of the following set of cell organelles are involved in the biosynthesis of jasmonic acid through octadecanoid signalling pathway?
1. Chloroplast and peroxisomes
  2. Chloroplast and mitochondria
  3. Mitochondria and peroxisomes
  4. Golgi bodies and mitochondria **Ans. 1**
35. The blastopore region of amphibian embryo that secretes BMP inhibitors and

40. Which of the following is **NOT** a prosthetic group of nitrate reductase?

- (1) FAD (2) Heme  
(3) Mo (4) Pterin

*Ans. 4*

41. Chloroplast distribution in a photosynthesizing cell is governed by blue light sensing phototropin 2 (PHOT2). When the cells are irradiated with high intensity blue light, the chloroplasts

- move to the side walls
- aggregate in the middle of the cell
- are sparsely distributed
- aggregate in small clusters

*Ans. 2*

42. Which of the following acts as a branch point for the biosynthesis of sesquiterpenes and triterpenes?

- Farnesyl pyrophosphate
- Geranyl pyrophosphate
- Isopentyl pyrophosphate
- Hydroxymethylglutaryl-CoA

*Ans. 1*

43. Which of the following waves is likely to be absent in a normal frog ECG?

- (1) P (2) Q  
(3) T (4) R

*Ans. 4*

44. The atmosphere in a sealed space craft contains

- pure oxygen
- a mix of oxygen and nitrogen
- a mix of oxygen and carbon dioxide
- pressurised atmospheric air available normally on earth

*Ans. 2*

45. In a normal human eye, for sharp image formation on the retina, maximum dioptric power is provided by the

- retina
- cornea

- anterior surface of the lens
- posterior surface of the lens

*Ans. 2*

46. In this flow diagram name the chemicals A, B, C and D in proper sequence.

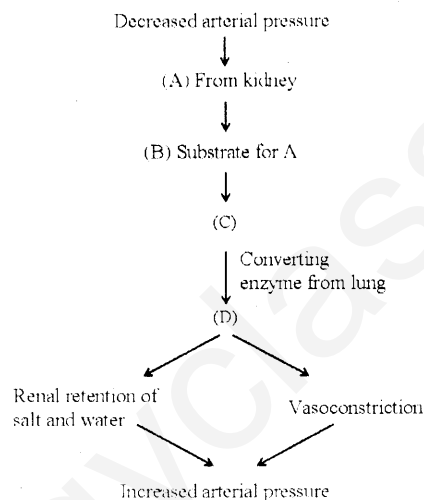

- Renin, Angiotensin II, Angiotensin I, Angiotensinogen
- Angiotensin I, Angiotensinogen, Angiotensin II, Renin
- Renin, Angiotensin I, Angiotensin II, Angiotensinogen
- Renin, Angiotensinogen, Angiotensin I, Angiotensin II

*Ans. 4*

47. A plant of the genotype AaBb is selfed. The two genes are linked and are 50 map units apart. What proportion of the progeny will have the genotype aabb?

- (1) 1/2 (2) 1/4  
(3) 1/8 (4) 1/16

*Ans. 4*

48. The base analog 2-aminopurine pairs with thymine, and can occasionally pair with cytosine. The type of mutation induced by 2-aminopurine is

- (1) transversion. (2) transition.  
(3) deletion. (4) nonsense.

*Ans. 2*



49. What kind of aneuploid gametes will be generated if meiotic non-disjunction occurs at first division? ('n' represents the haploid number of chromosomes)

1. only  $n+1$  and  $n$
2. only  $n-1$  and  $n$
3. both  $n+1$  and  $n-1$
4. either  $n+1$  or  $n-1$

**Ans. 3**

50. A single-strand nick in the parental DNA helix just ahead of a replication fork causes the replication fork to break. Recovery from this calamity requires

1. DNA ligase
2. DNA primase
3. site-specific recombination
4. homologous recombination

**Ans. 4**

51. In transverse sections of a young stem, if vallecular canals and carinal canals are present, then the plant belongs to

1. Lycopodiales
2. Isoetales
3. Selaginellales
4. Equisetales

**Ans. 4**

52. Horse shoe crabs belong to the group

1. Onychophora
2. Chelicerata
3. Uniramia
4. Crustacea

**Ans. 2**

53. Which of the following groups of species are typical of grassland habitats in India

1. Black buck, wolf, great Indian bustard, lesser florican
2. Spotted deer, dhole, peacock, finch-lark
3. Sambar, tiger, paradise fly catcher
4. Otter, cormorant, darter, pelican

**Ans. 1**

54. *Batrachochytrium dendrobatidis*, a fungus, has been implicated in the decline of populations of

- |              |           |
|--------------|-----------|
| (1) fish     | (2) frogs |
| (3) pelicans | (4) bats  |

**Ans. 2**

55. The Hutchinsonian concept of ecological niche is based on

1. microhabitat occupied
2. multidimensional hypervolume
3. role played in the ecosystem
4. a combination of role played and microhabitat occupied

**Ans. 2**

56. Which of the following is **NOT** a physiological characteristic of early successional plants?

1. High respiration rate
2. Inhibition by far-red light
3. High transpiration rate
4. Low photosynthetic rate

**Ans. 4**

57. Aquatic primary production was measured using Light-and-Dark Bottle technique. If the initial oxygen concentration was  $I$  and the final oxygen concentration in the light bottle was  $L$  and that in the dark bottle  $D$ , the gross productivity (in terms of oxygen released) is given as

- |             |             |
|-------------|-------------|
| (1) $L - I$ | (2) $I - D$ |
| (3) $I - L$ | (4) $L - D$ |

**Ans. 4**

58. Wetlands are conserved internationally through an effort called as

1. Basel Convention
2. Rio Convention
3. Montreal Convention
4. Ramsar Convention

**Ans. 4**

59. The first living beings on earth were anaerobic because

1. there was no oxygen in air
2. oxygen damages proteins

3. oxygen interferes with the action of ribozymes  
4. they evolved in deep sea **Ans. 1**
60. Which of the following processes interferes in sequence-based phylogeny?  
1. Horizontal gene transfer  
2. Adaptive mutations  
3. DNA repair  
4. Reverse transcription **Ans. 1**
61. The peacock's tail is an example of  
1. natural selection  
2. diversifying selection  
3. sexual selection  
4. group selection **Ans. 3**
62. A specialist species has a  
1. wider niche and high efficiency of niche utilization  
2. narrower niche and high efficiency of niche utilization  
3. wider niche and low efficiency of niche utilization  
4. narrower niche and low efficiency of niche utilization **Ans. 2**
63. To keep them in a totipotent state, embryonic stem cells need to be maintained in a medium supplemented with  
1. growth hormone  
2. leukemia inhibiting factor  
3. nestin  
4. insulin **Ans. 2**
64. Which of the following features is NOT shown by glyphosate, a broad spectrum herbicide?  
1. Little residual soil activity  
2. Ready translocation in phloem  
3. Inhibition of a chloroplast enzyme catalyzing the synthesis of aromatic amino acids  
4. Inhibition of early steps in the biosynthesis of branched chain amino acids **Ans. 4**
65. The rattans and canes that we use in furniture belong to  
(1) bamboos (2) palms  
(3) arborescent lilies (4) legumes **Ans. 1**
66. The presence of *Salmonella* in tap water is indicative of contamination with  
1. industrial effluents  
2. human excreta  
3. agriculture waste  
4. kitchen waste **Ans. 2**
67. Indirect immunofluorescence involves fluorescently labelled  
1. immunoglobulin-specific antibodies  
2. antigen-specific antibodies  
3. hapten-specific antibodies  
4. carrier-specific antibodies **Ans. 1**
68. A sample counted for one minute shows a count rate of 752 cpm. For how many minutes should it be counted to have 1 % probable error?  
(1) 13 (2) 5  
(3) 2 (4) 75 **doubt**
69. Measurement and mapping with spatial resolution the membrane potential of a cell, which is too small for microelectrode impalement, is done using  
1. radioisotope  
2. voltage-sensitive dye  
3. pH sensitive chemical  
4. vital dyes **Ans. 2**
70. One of the methods for finding common regulatory motifs present in a set of co-regulated genes is  
(1) Prosite (2) MEME  
(3) Mat Inspector (4) PSSM **Ans. 4**



75. Denaturation profiles of DNA are shown below.

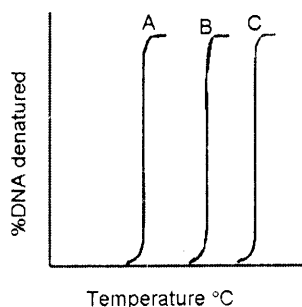

The differences in the profiles arise because

1. the DNA is single stranded but of different sizes
2. A + T content of A > B > C and the DNA are from complex genomes
3. G + C content of C > B > A in DNA of comparable sizes isolated from simple genomes
4. G + C content is identical but A + T content in A > B > C in DNA of comparable sizes isolated from simple genomes

**Ans. 3**

76. Biosynthesis of tyrosine is detailed below:

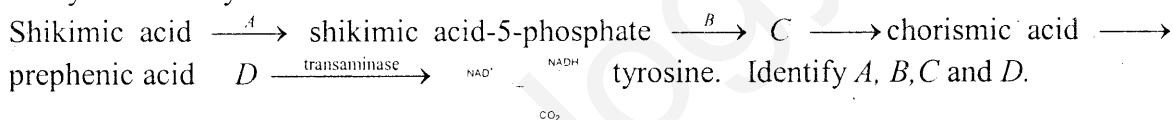

1. ATP, phosphoenolpyruvic acid, 3-enolpyruyl shikimic acid-5-phosphate, p-hydroxyphenylpyruvic acid
2. GTP, pyridoxal phosphate, 3-enolpyruvyl shikimic acid-5-phosphate, phenylpyruvic acid
3. NADP, 3-phosphohydroxypyruvic acid, 3-enolpyruvyl shikimic acid-5-phosphate, p-hydroxyphenylpyruvic acid
4. ATP, 3-phosphohydroxypyruvic acid, 3-enolpyruvyl shikimic acid-5-phosphate, pyridoxylphosphate

**Ans. 1**

77. A nerve impulse or action potential is generated from transient changes in the permeability of the axon membrane to  $\text{Na}^+$  and  $\text{K}^+$  ions. The depolarization of the membrane beyond the threshold level leads to  $\text{Na}^+$  flowing into the cell and a change in membrane potential to a positive value. The  $\text{K}^+$  channel then opens allowing  $\text{K}^+$  to flow outwards ultimately restoring membrane potential to the resting value. The  $\text{Na}^+$  and  $\text{K}^+$  channels operate in opposite directions because

1. there is an electrochemical gradient growth generated by proton transport
2. there is a difference in  $\text{Na}^+$  and  $\text{K}^+$  concentrations on either side of the membrane
3.  $\text{Na}^+$  is a voltage-gated channel, whereas  $\text{K}^+$  is ligand-gated
4.  $\text{Na}^+$  is dependent on ATP whereas  $\text{K}^+$  is not

**Ans. 2**

78. The erythrocyte membrane cytoskeleton consists of a meshwork of proteins underlying the membrane. The principal component spectrin has  $\alpha$ ,  $\beta$  subunits which assemble to form tetramers. The cytoskeleton is anchored to the membrane through linkages with the transmembrane proteins band 3 and glycophorin C. The cytosolic domain of band 3 also serves as the binding site of glycolytic enzymes such as glyceraldehyde 3-phosphate dehydrogenase. Analysis of the blood sample of a patient with haemolytic anemia shows spherical red blood cells. The patient carries

1. a mutation in glycophorin C
2. a mutant spectrin with increased tetramerization propensity
3. mutant  $\beta$  spectrin defective in  $\alpha\beta$  dimerization ability
4. mutant glyceraldehyde 3-phosphate dehydrogenase

**Ans. 3**

79. In human, protein coding genes are mainly organized as “exons” and “introns”. There are intergenic regions that transcribe into various types of non-coding RNA (not translating into protein). Some introns may harbor also transcription units, which are

1. always other protein coding genes
2. protein coding gene and RNA coding genes
3. always RNA coding genes
4. pseudo genes

**Ans. 4**

80. Maturation-promoting factor (MPF) controls the initiation of mitosis in eukaryotic cells. MPF kinase activity requires cyclin B. Cyclin B is required for chromosome condensation and breakdown of the nuclear envelope into vesicles. Cyclin B degradation is followed by chromosome decondensation, nuclear envelope reformation and exit from mitosis. This requires ubiquitination of a cyclin destruction box motif in cyclin B. RNase-treated *Xenopus* egg extracts and sperm chromatin were mixed. MPF activity increased with chromosome condensation and nuclear envelope breakdown. However, this was not followed by chromosome decondensation and nuclear envelope reformation because

1. RNase contamination persisted in the system
2. cyclin B was missing from the system
3. ubiquitin ligase had been overexpressed
4. cyclin B lacking the cyclin destruction box had been overexpressed

**Ans. 4**

81. Many cancers carry mutant p53 genes, while some cancers have normal p53 genes. p53 activates p21 (Waf1) which inhibits G1/S-Cdks and phosphorylation of the retinoblastoma protein (Rb). Cancers with normal p53 genes could

1. express non-phosphorylatable form of Rb
2. express high levels of p53-deubiquitinases
3. express inactive forms of G1/S-cdks
4. express inactive forms of G1/S cyclins.

**Ans. 4**

82. A fixed smear of a bacterial culture is subjected to the following solutions in the order listed below and appeared red.

(a) Carbofuchsin (heated)                      (b) Acid-alcohol                      (c) Methylene blue

Bacteria stained by this method can be identified as

- (1) Non-acid fast *E. coli*                      (2) Acid-fast *Mycobacterium sp.*  
(3) Gram-positive *E. coli*                      (4) Gram-negative *Mycobacterium sp.*

Ans. 2

83. In an *in vitro* experiment using radiolabelled nucleotides, a researcher is trying to analyze the possible products of DNA replication, by resolving the products using urea-polyacrylamide gel electrophoresis. In one experimental set up RNase H was added (Set 1), while in another set no RNase H was added (Set 2).

The possible observations of this experiment could be

- A. There is no difference in the mobility of labelled DNA fragments between the Set 1 and Set 2  
B. There is distinct difference in the mobility of the newly synthesized labelled DNA fragments between Set 1 and Set 2  
C. The mobility of the newly synthesized labelled DNA fragments in case of Set 1 is faster as compared to the Set 2  
D. The mobility of the newly synthesized labelled DNA fragments in case of Set 1 is slower as compared to the Set 2

Which of the following combinations represent correct observations?

- (1) A and B                      (2) B and C                      (3) A and D                      (4) B and D

Ans. 2

84. Synthesis of normal hemoglobin requires coordinated synthesis of  $\alpha$  globin and  $\beta$  globin. Thalassemias are genetic defects perturbed in this coordinated synthesis. Patients suffering from deficiency of  $\beta$  globin chains ( $\beta$ -thalassemia) could also be due to mutations affecting the biosynthesis of  $\beta$  globin mRNA.

The following statements describe the genesis of non-functional  $\beta$  globin leading to  $\beta$ -thalassemia.

- A. Mutation in the promoter region of the  $\beta$  globin gene.  
B. Mutation in the splice junction of the  $\beta$  globin gene.  
C. Mutation in the intron I of the  $\beta$  globin gene.  
D. Mutations towards the 3' end of the  $\beta$  globin gene that codes for polyadenylation site.

Which of the following combinations is correct?

- (1) A, B and D                      (2) A, B and C  
(3) B, C and D                      (4) C, D and A

*Ans. 1*

85. Pre-mRNAs are rapidly bound by snRNPs which carry out dual steps of RNA splicing, that removes the intron and joins the upstream and downstream exons.

The following statements describe some facts related to this event.

- A. Almost all introns begin with GU and end with AG sequences and hence all the GU or AG sequences are spliced out of RNA.  
B. U2 RNA recognizes important sequences at the 3' acceptor end of the intron.  
C. The spliceosome uses ATP to carry out accurate removal of intron.  
D. An unusual linkage with 2' OH group of guanosine within the intron form a 'Lariat' structure.

Which of the following combinations is correct ?

- (1) A and B                              (2) B and C  
(3) C and D                              (4) D and A

*Ans. 1*

86. For continuation of protein synthesis in bacteria, ribosomes need to be released from the mRNA as well as to dissociate into subunits. These processes do not occur spontaneously. They need the following possible conditions:

- A. RRF and EF-G aid in this process  
B. An intrinsic activity of ribosomes and an uncharged tRNA are required  
C. IF-1 promotes dissociation of ribosomes  
D. IF-3 and IF-1 promote dissociation of ribosomes

Which of the following sets is correct ?

- (1) A and D              (2) A and B              (3) A and C              (4) B and D              *Ans. 1*

87. Insulin and other growth factors stimulate a pathway involving a protein kinase mTOR, which in its turn augments protein synthesis. mTOR essentially modifies protein(s) which in their unmodified form act as inhibitors of protein synthesis. The following proteins are possible candidates:

- A. eEF-1              B. eIF-4E-BP1              C. eIF-4E              D. PHAS-1

Which of the following sets is correct ?

- (1) A and B      (2) B and D      (3) A and C      (4) B and C

**Ans. 2**

88. Bacteriophage  $\lambda$  has two modes in its life cycle, lytic and lysogenic. In the lysogenic mode, the expression of all the phage genes are repressed while the expression of repressor gene switches between on and off position depending on the concentration of repressor. The following statements are made :

- A. Repressor may act both as a positive regulator and a negative regulator  
 B. Expression of repressor gene, cI is independent of the expression of cII and cIII genes.  
 C. Mutation of cI gene will cause it to form, clear plaques on both wild type *E. coli* and *E. coli* ( $\lambda^+$ ).  
 D. Mutation at operators,  $O_L$  and  $O_R$  will allow the phage to act as a virulent phage.

The correct statements are

- (1) A and B      (2) B and C      (3) C and D      (4) D and A

**Ans. 4**

89. Survival of intracellular pathogens depends on the levels of pro-inflammatory and anti-inflammatory cytokines in macrophages. In an experimental condition, *Mycobacteria* infected macrophages were treated with IL-6 or IL-12 for 4 hours at 37°C. Untreated cells were used as control. Cells were lysed and number of bacteria in each experimental set was counted by measuring colony forming unit (CFU). Which of the following observations is true?

1. IL-12 treated cells contain more intracellular bacteria than control
2. IL-12 treated cells contain less intracellular bacteria than control
3. IL-6 treated cells contain more intracellular bacteria than control
4. IL-6 treated cells contain less intracellular bacteria than control

**Ans. 2**

90. The bacterial flagellar motor is a multi-protein complex. Rotation of the flagellum requires movement of protons across the membrane facilitated by a multi-protein complex. The flagellar motor proteins combine to create a proton channel that drives mechanical rotation. In a screen for mutants, some non-motile ones were selected. These could have

1. mutations in tubulin and actin proteins
2. mutations in kinesin proteins
3. mutated  $H^+$ -ATPase
4. mutations in the charged residues lining the ridge of the FliG subunit

**Ans. 3**



91. A bacterial response regulator turns on gene A in its phosphorylated form. The amount of "A" shows a sharp and steep rise at a threshold concentration of the signal sensed by the cognate sensor. This is most likely due to

1. increased phosphatase activity of the sensor at the threshold concentration
2. decreased phosphorylation of the response regulator by the sensor
3. cooperativity in binding of the response regulator to the target gene A
4. negative feed back in gene A expression

*Ans. 1*

92. Intracellular transport and cytoskeletal organization of a cell is regulated by nucleotide exchange of different small molecular weight GTPases of Ras super family. Overexpression of which of the following GTPase modulates the actin-cytoskeleton of HeLa cells?

- |                           |                           |
|---------------------------|---------------------------|
| (1) Ran in GDP bound form | (2) Ran in GTP bound form |
| (3) Rho in GTP bound form | (4) Rho in GDP bound form |

*Ans. 3*

93. You are given a group of four mice. Each mouse is immunized with keyhole limpet hemocyanin or azobenzene arsonate or lipopolysaccharide or dextran. Four weeks later, sera were collected from these mice and antigen-specific IgG1 and IgG2a ELISA were performed. Only one of the mice showed positive response. It was

1. keyhole limpet hemocyanin-primed mouse
2. azobenzene arsonate-primed mouse
3. lipopolysaccharide-primed mouse
4. dextran-primed mouse

*Ans. 1*

94. Tumor cells were isolated from a breast cancer patient. These cells were injected into nude mice and they were divided into four groups. Group 1 received EGF receptor-conjugated with methotrexate; Group 2 received transferrin receptor-conjugated with methotrexate; Group 3 received mannose receptor-conjugated with methotrexate; Group 4 received same amount of the free drug. In which of the following cases tumorigenic index would be minimum?

1. Free drug
2. EGF receptor-conjugated drug
3. Transferrin receptor-conjugated drug
4. Mannose receptor-conjugated drug

*Ans. 3*

Please visit: [www.easybiologyclass.com](http://www.easybiologyclass.com) for:

- Lecture Notes
- Biology PPTs
- Biology MCQs
- Online Mock Tests (MCQ)
- Video Tutorials
- Practical Aids
- Model Question Papers of NET, GATE, DBT, ICMR Exams
- CSIR NET Life Sciences Previous Year Question Papers
- GATE Previous Year Question Papers
- DBT BET JRF Previous Year Question Papers
- ICMR JRF Entrance Exam Resources
- Jobs Notifications
- Higher Studies in Biology / Life Sciences
- Seminar / Workshop/ Conference Notifications
- And many more....



Please subscribe our **youtube** channel: **easybiologyclass**  
<https://www.youtube.com/user/easybiologyclass/videos>



You can access more PDFs & PPTs from our **Slideshare** account  
<http://www.slideshare.net/EasyBiologyClassEBC/>



Our sister concern: [www.angiospermtaxonomy.com](http://www.angiospermtaxonomy.com)

95. When the prospective neurons from an early gastrula of a frog were transplanted into the prospective epidermis region, the donor cells differentiated into epidermis. However, when a similar experiment was done with the late gastrula of frog, the prospective neurons developed into neurons only. These observations could possibly be explained by the following phenomena.
- The early gastrula show conditional development whereas the late gastrula shows autonomous development.
  - The early gastrula show autonomous development whereas the late gastrula shows conditional development.
  - The prospective neurons from the early gastrula are only specified whereas those from the late gastrula are determined.
  - The prospective neurons from the early gastrula are determined whereas those from the late gastrula are specified.

Which of the conclusions drawn above are correct?

- (1) A and B    (2) A and C    (3) A and D    (4) B and C

**Ans. 2**

96. AP1 (*APETLA 1*) is one of the floral meristem identifying genes. In wild type *Arabidopsis thaliana* plants transformed with AP1::GUS,  $\beta$  glucuronidase (GUS) activity is seen in floral meristem, only after the commitment to flowering. Ectopic expression of AP1::GUS in the *EMBRYONIC FLOWER (emf)* mutant background results in GUS activity throughout the shoots in four day old seedlings. These observations suggest that AP1 is:

- not involved in flowering
- involved in repression of flowering
- involved in promoting flowering
- stimulation of flowering in the *emf* background

**Ans. 4**

97. In case of morphallactic regeneration:

- there is repatterning of the existing tissues with little new growth
- there is repatterning of the existing tissues after the stem cell division has taken place
- there is cell division of the differentiated cells which maintain their differentiated state to finally form a complete organism.
- there is dedifferentiation of the cells at the cut surface which become undifferentiated. These undifferentiated cells then divide to redifferentiate to form the complete structure

**Ans. 1**

98. The decision to become either a trophoblast or inner cell mass blastomere is one of the first decisions taken by any mammalian embryo. Below is a diagrammatic representation of the different cells formed during development from the morula with the help of different molecules. Identify the molecules 1-4, sequentially.

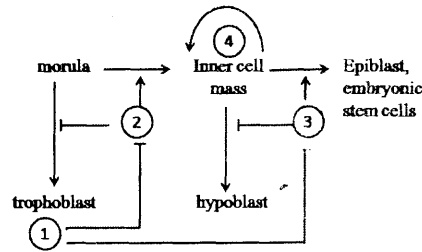

- (1) cdx 2, Oct 4, Nanog, Stat 3      (2) cdx 2, Nanog, Stat 3, Oct 4  
 (3) cdx 2, Nanog, Oct 4, Stat 3      (4) cdx 2, Oct 4, Stat 3, Nanog

**Ans. 3**

99. With respect to the extra embryonic structures formed in the mammals, the possible functional attributes have been designated:

- A. Allantoin stores urinary waste and helps mediate gas exchange. It is derived from splanchnopleure at the caudal end of the primitive streak.  
 B. Amnion is a water sac and protects the embryo and its surrounding amniotic fluid. This epithelium is derived from somatopleure.  
 C. Chorion is essential for gas exchange in amniote embryos. It is generated from the splanchnopleure.  
 D. Yolk sac is the last embryonic membrane to form and is derived from somatopleure.

Which of the above statements are correct?

- (1) A and B      (2) A and C      (3) B and C      (4) A and D

**Ans. 3**

100.

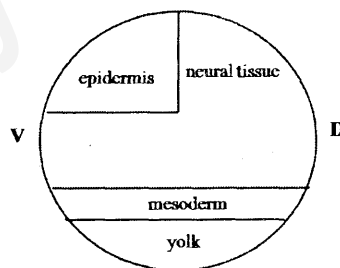

The figure above represents a late zebrafish gastrula. The following concepts may be proposed during further development of the embryo.

- A. The concentration of FGF decreases from the yolk towards the epidermis, along with the increase of BMP activity from the dorsal to the ventral axis.
- B. Increase in FGF activity in the epidermis with concomitant decrease in BMP activity towards the ventral axis.
- C. Neural induction in zebrafish is independent of the organizer and depends on activation of BMP signalling.
- D. In comparison, both *Xenopus* and chick embryos require activation of FGF for neural induction to occur in addition to BMP inhibition.

Which of the above statements are true?

- (1) A and C                      (2) B and C                      (3) A and D                      (4) C and D

**Ans. 2**

101. Following are some of the statements regarding the effect of CO<sub>2</sub> concentration on photosynthesis in plants.

- A. With elevated CO<sub>2</sub> levels, C<sub>3</sub> plants are much more responsive than C<sub>4</sub> plants under well watered conditions.
- B. In C<sub>3</sub> plants, increasing intracellular CO<sub>2</sub> partial pressure can stimulate photosynthesis only over a narrow range.
- C. In C<sub>4</sub> plants, CO<sub>2</sub> compensation point is nearly zero.

Which one of the following combination of above statements is correct?

- (1) A and B                      (2) B and C                      (3) A and C                      (4) Only C

**Ans. 3**

102. The quantum yield of photosynthetic carbon fixation in a C<sub>3</sub> plant and C<sub>4</sub> plant is studied as a function of leaf temperature. Following are some statements based on this study.

- A. At lower temperature the quantum yield of C<sub>3</sub> plant is lower than C<sub>4</sub> plant.
- B. In C<sub>4</sub> plant quantum yield does not show a temperature dependence.
- C. Since the photorespiration is low in C<sub>4</sub> plants because of CO<sub>2</sub> concentrating mechanism, quantum yield is not affected.
- D. At higher temperature the quantum yield of C<sub>3</sub> plant is lower than C<sub>4</sub> plant.

Which one of the following combination of above statements is correct?

- (1) A, B and D                      (2) B, C and D                      (3) A, B and C                      (4) A, C and D

**Ans. 2**

103. Following are some statements regarding plant growth hormones.

- A. Ethylene regulates abscission.
- B. Gibberlins do not play any role in flowering.
- C. Auxin and cytokinin promote cell division.
- D. Over expression of cytokinin oxidase would promote root growth.
- E. ABA inhibits root growth and promotes shoot growth at low water potential.
- F. ABA promotes leaf senescence independent of ethylene.

Which one of the following combination of above statements is correct?

- (1) A, C and F            (2) B, C and D            (3) D, E and F            (4) B, D and E

*Ans. 1*

104. Following are some statements for synthesis of jasmonic acid in plants

- A. 12-oxo-phytodienoic acid is produced in chloroplast and transported to peroxisome.
- B. Action of lipoxygenase, allene oxide synthase and allene oxide cyclase takes place in peroxisome.
- C. 12-oxo-phytodienoic acid is first reduced and then converted to jasmonic acid by  $\beta$ -oxidation.
- D. Final production of jasmonic acid takes place in chloroplast.
- E. Action of allene oxide synthase and allene oxide cyclase takes place in chloroplast.

Which one of the following combination of above statements is correct?

- (1) A, B and C            (2) B, D and E            (3) C, D and E            (4) A, C and E

*Ans. 4*

105. Following are some statements about low temperature stress in plants.

- A. Fatty acid composition of mitochondria isolated from chilling resistant and chilling sensitive plants differs significantly.
- B. Ratio of unsaturated fatty acids to saturated fatty acids is lower in chilling resistant species.
- C. The cellular water does not freeze even at  $-40^{\circ}\text{C}$ , because of the presence of solutes and other antifreeze proteins.
- D. Heat shock proteins do not play any role during low temperature stress.

Which one of the following combination of above statement is correct?

- (1) A and B            (2) A and C            (3) B and C            (4) B and D

*Ans. 2*

106. An isolated carotid sinus was prepared so that the pressure may be regulated by a pump and the resulting discharge in single carotid sinus nerve fibre could be recorded. The following are the possible observations.

- A. No discharge when carotid sinus perfusion pressure was below 30 mm Hg.
- B. Linear increase in discharge frequency when carotid sinus perfusion pressure was gradually increased from 70 to 110 mm Hg.
- C. Increase in discharge frequency was more prominent in greater pulsatile changes of carotid sinus pressure keeping the mean pressure identical in all cases.
- D. Increase in discharge was more prominent in the falling phase of pulsatile change of carotid sinus pressure than in the rising phase.

Which one of the following is correct?

- (1) A, B and C                      (2) A and C                      (3) B and D                      (4) D only

**Ans. 3**

107. For a normal heart, the time taken for atrial systole and diastole are  $A_s$  and  $A_d$  seconds, respectively, while the same for ventricular systole and diastole are  $V_s$  and  $V_d$ . Which one of the following equations is correct ?

- (1)  $A_s + A_d = V_s + V_d$                       (2)  $A_s + A_d < V_s + V_d$   
 (3)  $A_s + A_d - V_s + V_d = 0$                       (4)  $A_s + A_d > V_s + V_d$

**Ans. 2**

108. During the spanish conquest of the Inca Empire at the high altitude in Peru, many soldiers fell sick. It was found that the sickness was due to low partial pressure of  $O_2$  in the atmosphere at that altitude. To determine the reason, blood was collected from those patients. The circulating erythropoietin (EPO) level were estimated and the  $O_2$ -dissociation curve of haemoglobin were drawn and compared with the same in native people as depicted below.

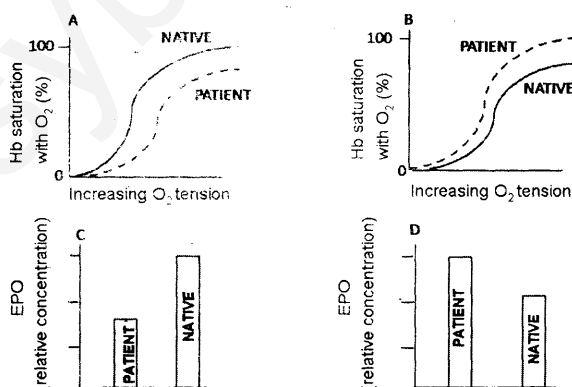

Which one of the following combinations is logically correct ?

- (1) A and C                      (2) A and D                      (3) B and C                      (4) B and D

**Ans. 1**

109. A monkey undergoes cerebellectomy. After the post-operative recovery, the monkey was given a task to press a bar. The possible observations are:

- A. Its hand would overshoot the target while reaching the bar.
- B. It would be unable to move forelimbs.
- C. It would show intention tremor while trying to press the bar.
- D. It would press the bar with mouth instead of hand.

Which one of the following is correct?

- (1) A and C      (2) B only      (3) D only      (4) B and D

**Ans. 1**

110. A 1 meter tall object was placed 10 meter in front of a normal eye. The size of the image on the retina will be (consider distance between lens and retina = 1.7 cms)

- (1) 0.17 mm      (2) 1.7 mm      (3) 3.4 mm      (4) 170  $\mu\text{m}$

**Ans. 2**

111. The graph represents relative plasma concentration of hormones (A and B) during reproductive cycle in a normal female. Which one of the following combinations is correct?

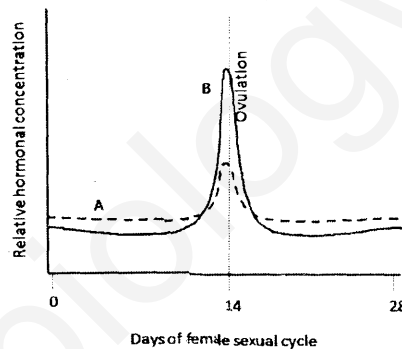

- (1) (A) is FSH and (B) is estrogen      (2) (A) is estrogen and (B) is LH  
 (3) (A) is FSH and (B) is LH      (4) (A) is LH and (B) is FSH

**Ans. 3**

112. The following figure depicts the relationship between a genetic map for four genes (A, B, C and D) and their corresponding physical map:

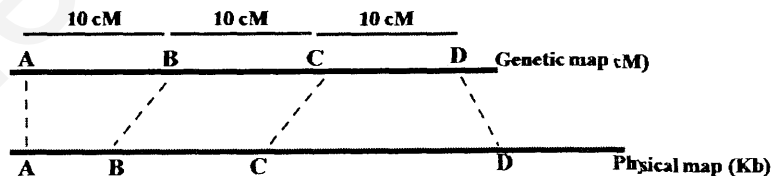

The following statements are made to explain this relationship.



The following statements are made to explain this relationship.

- A. More number of recombination events occur between *A* and *B* as compared to *B* and *C*.
- B. Lesser number of recombination events occur between *C* and *D* as compared to *B* and *C*.
- C. Although the physical distance between *A* and *B* is less than that between *C* and *D*, the region between *A* and *B* is more recombinogenic.
- D. The physical distance between *A* and *B* is less than that between *C* and *D*, and thus the region between *A* and *B* is less recombinogenic.
- E. Although the physical distance between *C* and *D* is more than that between *B* and *C*, the region between *C* and *D* is less recombinogenic.
- F. Although the physical distance between *C* and *D* is more than *B* and *C*, the region between *C* and *D* is more recombinogenic.

Which statements are correct?

- (1) A and B      (2) C and E      (3) D and F      (4) A, C and E

Ans. 4

113. Consider the following crosses involving grey (wild-type) and yellow body colour true-breeding *Drosophila*:

	Cross	F <sub>1</sub> progeny	F <sub>2</sub> progeny
Cross 1	Grey female X yellow male	All males : grey All females : grey	Grey females: 98 Yellow males: 45 Grey males: 49
Cross 2	Yellow females X grey males	All males : yellow All females: grey	?

Assuming 200 F<sub>2</sub> offsprings are produced in cross 2, which one of the following outcome is expected?

- 1. 97 grey males, 54 yellow females, 49 grey males
- 2. 102 yellow males, 46 yellow females, 52 grey females
- 3. 52 grey males, 49 yellow males, 48 yellow females, 51 grey females
- 4. 98 grey males, 94 yellow females, 2 yellow males, 6 grey females

Ans. 3

114. The ABO blood type in human is under the control of autosomal multiple alleles. Colour blindness is recessive X-linked trait. A male with a blood type A and normal vision marries a female who also has blood type A and normal vision. The couple's first child is a male who is colour blind and has O blood group. What is the probability that their next female child has normal vision and O blood group?

- (1) 1/4      (2) 3/4      (3) 1/8      (4) 1

Ans. 3

115. In *E. coli* four Hfr strains donate the following genetic markers in the order shown below:

- Strain 1: L Q W X Y
- Strain 2: M T A D Y
- Strain 3: E C M T A
- Strain 4: W Q L E C

Which of the following depicts the correct order of the markers and the site of integration (►) of the F-factor in the four Hfr strains?

(1)

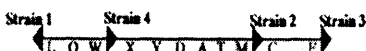

(2)

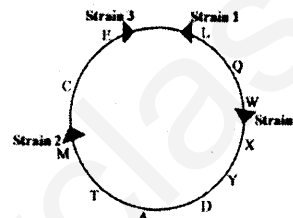

(3)

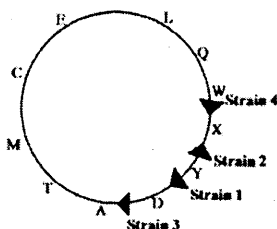

(4)



Ans. 2

116. The following is a schematic representation of region (showing six bands) of the polytene chromosome of *Drosophila*, along with the extent of five deletions (Del1 to Del5):

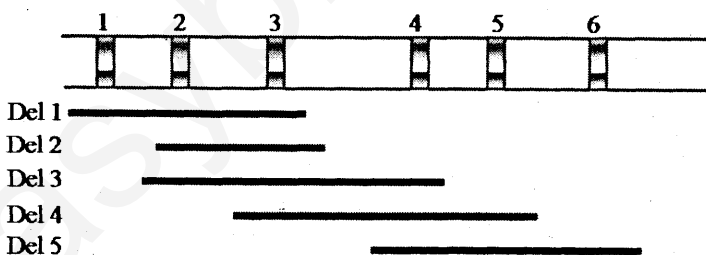

Recessive alleles *a*, *b*, *c*, *d*, *e* and *f* are known to correspond to each of the bands (1 to 6), but their order is not known. When the recessive alleles are placed against each of these deletions, the following results are obtained. The plus (+) in the table indicates wild type phenotype of the corresponding allele, while a minus (-) indicates the phenotype governed by the corresponding mutant allele.

	<i>a</i>	<i>b</i>	<i>c</i>	<i>d</i>	<i>e</i>	<i>f</i>
Del 1	+	-	-	-	+	+
Del 2	+	+	-	-	+	+
Del 3	-	+	-	-	+	+
Del 4	-	+	+	-	-	+
Del 5	-	+	+	+	-	-

Which one of the following indicates the correct location of the recessive alleles on the bands of the polytene chromosomes?

- (1) *a* - 3; *b*-1 ; *c*-2 ; *d*-4 ; *e*-5 ; *f*-6.      (2) *a* - 2; *b*-1 ; *c*-3 ; *d*-4 ; *e*-5 ; *f*-6.  
 (3) *a* - 4; *b*-1 ; *c*-2 ; *d*-3 ; *e*-5 ; *f*-6.      (4) *a* - 6; *b*- 2; *c*- 3; *d*- 4; *e*- 1; *f*-5.

**Ans. 3**

117. Assuming a 1: 1 sex ratio, what is the probability that three children from the same parents will consist of two daughters and one son?

- (1) 0.375      (2) 0.125      (3) 0.675      (4) 0.75

**Ans. 1**

118. Chlorophyll pigment composition and carbohydrate food reserves of some algal groups are given below:

Pigments: (i) Chlorophyll *a* and *b*; (ii) Chlorophyll *a* and *c*.

Carbohydrate food reserve: (a) Paramylon; (b) Starch; (c) Laminarin; (d) Leucosin.

Identify the correct combination of the characters for the given groups.

- Euglenophyta – (i and a); Bacillariophyta – (ii and d); Phaeophyta – (ii and c); Chlorophyta – (i and b)
- Euglenophyta – (ii and a); Bacillariophyta – (ii and d); Phaeophyta – (i and c); Chlorophyta – (i and b)
- Euglenophyta – (i and a); Bacillariophyta – (ii and b); Phaeophyta – (i and c); Chlorophyta – (ii and d)
- Euglenophyta – (i and d); Bacillariophyta – (ii and a); Phaeophyta – (ii and c); Chlorophyta – (i and b)

**Ans. 1**

119. Identify the synapomorphies in the following cladogram:

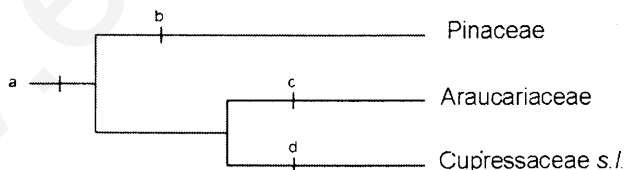

1. (a) seeds with long terminal wing; (b) ovules 1-20 per scale; (c) resin canals; (d) 1 ovule per scale
2. (a) resin canals; (b) seeds with long terminal wing; (c) 1 ovule per scale; (d) ovules 1-20 per scale
3. (a) resin canals; (b) ovules 1-20 per scale; (c) seeds with long terminal wing; (d) 1 ovule per scale
4. (a) seeds with long terminal wing; (b) ovules 1-20 per scale; (c) 1 ovule per scale; (d) resin canals

*Ans. 2*

120. From among the five animals listed below, match the two attributes – amniotic egg and endothermy, with the correct animal(s):

- (a) fish      (b) frog      (c) crocodile      (d) pigeon      (e) zebra

1. Amniotic egg: b, c, d; Endothermy: d, e
2. Amniotic egg: c, d, e; Endothermy: d, e
3. Amniotic egg: a, b, c, d; Endothermy: c, d, e
4. Amniotic egg: b, c, d; Endothermy: c, d, e

*Ans. 2*

121. During a field study, three insects with the following characteristics were observed:

- A: elongate, membranous wings with netlike venation, long and slender abdomen, large compound eyes  
B: small bodied, sucking mouth parts, narrow wings fringed with setae  
C: sclerotized forewings, membranous hindwings, chewing mouth parts

They can be identified to their respective orders as

1. A - Orthoptera; B-Hemiptera; C-Coleoptera
2. A - Odonata; B-Coleoptera; C-Hemiptera
3. A - Orthoptera; B - Odonata; C-Coleoptera
4. A - Odonata; B-Thysanoptera; C-Coleoptera

*Ans. 1*

122. Several distinct time periods and different routes might explain the entrance of marsupials into Australia.

- (i) Late Jurassic – early therians arrived in Antarctica – Australia where the marsupials subsequently evolved.
- (ii) Early to middle Cretaceous – early marsupials arrived in Australia from northern regions and then radiated in isolation.
- (iii) Paleocene – marsupials entered Australia from South-East Asia.
- (iv) Eocene – chance dispersal of marsupials into Australia.

Which of the following is the correct combination?

- (1) (i) (ii) (iii)                      (2) (i) (iii) (iv)  
(3) (ii) (iii) (iv)                      (4) (i) (ii) (iv)

*Ans. 2*

123. Which of the following is **NOT** true for a critically endangered species?

1. Reduction of population breeding ability due to increased relatedness through the action of incompatibility mechanisms in plants or behavioural difficulties in animals.
2. The individuals of the species which have declined to low numbers are still a genetically open system.
3. Loss of some alleles from the species causing loss of genetic diversity with consequent inability to respond rapidly to selection.
4. Expression of deleterious alleles and increased homozygosity increases mortality of young, and inbreeding depression leads to reduced offspring fitness.

*Ans. 2*

124. Ecological compression differs from character displacement in that it operates on a

1. shorter timescale and does not involve heritable change.
2. longer timescale and does not involve heritable change.
3. shorter timescale and involves heritable change.
4. longer timescale and involves heritable change.

*Ans. 1*

125. Autotrophs in the aquatic ecosystem, unlike their counterparts in the terrestrial ecosystem, are mostly microscopic and very low in indigestible (to the herbivores) matter. This explains the fact that compared to the terrestrial ecosystem, in the aquatic ecosystem

1. Productivity/Biomass ratios are higher and energy transfer rates to higher trophic levels are faster.
2. Productivity/Biomass ratios are lower and the energy transfer rates to higher trophic levels are slower.
3. Productivity/Biomass ratios are lower and the energy transfer rate to higher trophic levels are faster.
4. Productivity/Biomass ratios are higher and the energy transfer rate to higher trophic levels are slower.

*Ans. 1*

126. Which of the following graphs illustrates the current consensus on the role of *disturbance* on the species richness of a community?

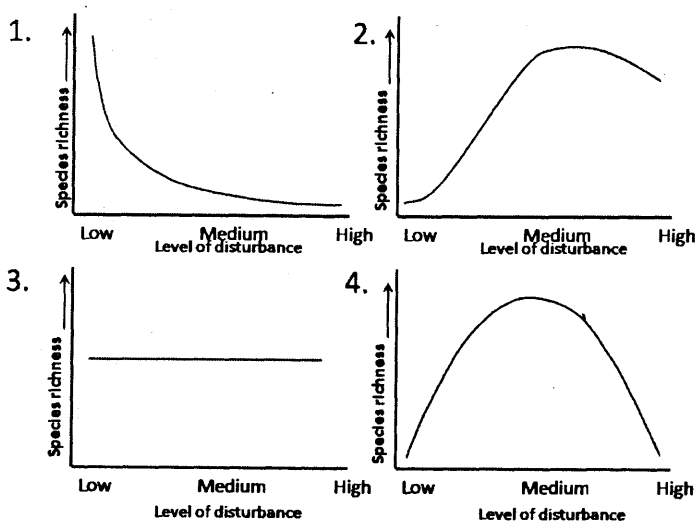

Ans. 4

127. In the global nitrogen cycle, the following microbial organisms are involved in three important process – denitrification, nitrification and nitrogen fixation.

(a) *Rhizobium* (b) *Nitrosomonas* (c) *Nitrobacter* (d) *Pseudomonas* (e) *Azotobacter*.

Which of the following is the correctly matched pair of process and its causative species?

- Denitrification - (b); nitrogen fixation - (c) and (e); nitrification - (d)
- Denitrification - (d); nitrogen fixation - (a) and (e); nitrification - (c)
- Denitrification - (e); nitrogen fixation - (a) and (d); nitrification - (d)
- Denitrification - (b); nitrogen fixation - (a) and (d); nitrification - (c)

Ans. 2

128. Suppose you discovered a new species about which you know only two facts: it is small-sized (<10 cm) and short-lived (<20d). Which of the following reproductive strategies is most likely to be true for this species?

- Breeds early and more than once in life and produces large number of small-sized offspring.
- Breeds late and only once in life and produces large number of small-sized offspring.
- Breeds early and only once in life and produces large number of small-sized offspring.
- Breeds early and only once in life and produces a small number of large-sized offspring.

Ans. 3

129. The genetic relatedness ( $r$ ) of an individual to his nephew is 0.25. The alleles that cause uncles to care for nephews will spread, according to Hamilton's Rule, only if the fitness benefit is

- (1) equal to the cost of care. (2) more than the cost of care by 25%.  
 (3) double the cost of care. (4) four times the cost of care. **Ans. 4**

130. The frequencies of two alleles  $p$  and  $q$  for a gene locus in a population at Hardy-Weinberg equilibrium are 0.3 and 0.7, respectively. After a few generations of inbreeding, the heterozygote frequency was found to be 0.28. The inbreeding coefficient in this case is

- (1) 0.42. (2) 0.28. (3) 0.33. (4) 0.67. **Ans. 3**

131. Which of the following behavioural changes are expected in a rat when its nucleus accumbens is experimentally ablated?

- (1) Aggressive behaviour increases (2) Exploratory behaviour decreases  
 (3) Nest-building activity increases (4) Level of parental care drops

**Ans. 1**

132. Number of trials required for rats to learn a task when they were exposed to various conditions were as follows:

<u>Experimental Conditions</u>	<u>Observations</u>
A Light: light dark cycle – 12h: 12h	N – trials
B Bright light – 24 h	Significantly more trials than 'N'
C Bright light – 24 h + continuous physical disturbance	Significantly more trials than 'N'
D Dark light – 24h + continuous physical disturbance	Significantly more trials than 'N'

Which of the following inferences is most appropriate?

- (1) Continuous light enhanced learning (2) Continuous darkness inhibited learning  
 (3) Physical activity inhibited learning (4) Learning was reduced by sleep loss

**Ans. 4**

133. Assume a male sparrow (species X) is hatched and reared in isolation and allowed a critical imprinting period to hear the song of a male of another sparrow (species Y). Now after the isolation, what kind of behaviour will species X show?

1. It will sing the song of species Y that it had heard in the critical period.
2. It will sing the song of its own species X.
3. It will not sing at all.
4. It will sing a song not sung by either X or Y.

**Ans. 1**

134. Enzymes are nowadays used extensively in bioprocessing industries. Enzyme 1 is used for treatment of hides to provide a finer texture, in leather processing and manufacture of glue. Enzyme 2 is used for clarification of fruit juices.

Identify Enzymes 1 and 2

Enzyme 1	Enzyme 2
1. Amylase	Pectinase
2. Protease	Amylase
3. Protease	Pectinase
4. Pectinase	Amylase

**Ans. 3**

135. In order to prevent tetanus in neonates, one of the following treatments can be adopted.

- A. Treatment of the infant with anti-toxin and the toxoid.
- B. Immunize the mother with the toxoid.

In case of A, the treatment can be given

- a. immediately after birth
- b. after the onset of the condition.

In case of B, the immunization has to be done

- c. before pregnancy.
- d. late in the pregnancy.

The correct combination is

- (1) A/a      (2) A/b      (3) B/c      (4) B/d      **doubt**

136. Genomic DNA of transgenic plants (P1, P2 and P3) obtained by transforming with binary vector A whose map is depicted below, was digested with BamH I and Sal I and hybridized with a labelled fragment X

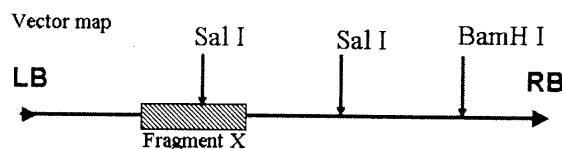



The pattern obtained in Southern hybridization is shown below:

P1		P2		P3	
BamH I	Sal I	BamH I	Sal I	BamH I	Sal I
	—	—		—	—
—	—		—		
—	—		—		—

Based on the above, which of the following interpretations is correct:

1. All the plants (P<sub>1</sub>, P<sub>2</sub> and P<sub>3</sub>) contain two copies of the transgene
2. P<sub>1</sub>, P<sub>3</sub> contain one and P<sub>2</sub> contains two copies of the transgene
3. P<sub>1</sub> contains two, whereas P<sub>2</sub> and P<sub>3</sub> contain one copy of transgene each
4. P<sub>1</sub> and P<sub>2</sub> contains two and P<sub>3</sub> contains one copy of the transgene

**Ans. 3**

137. The following are statements about molecular markers in the context of plant breeding.

- A. Molecular markers can be used for elimination of undesirable traits.
- B. Molecular markers cannot be used for estimation of the genetic contribution of each individual parent in a segregating population.
- C. Molecular markers are used for mapping of QTLs, which is also possible by conventional techniques.
- D. Molecular markers can be used for selection of individuals from a population that are homozygous for the recurrent parent genotype at loci flanking the target locus.

Which of the above statements are TRUE?

- (1) A and B      (2) A and C      (3) A and D      (4) B and C

**Ans. 3**

138. In 'TaqMan' assay for detection of base substitutions (DNA variant), probes (oligonucleotides) with fluorescent dyes at the 5'-end and a quencher at 3'-end are used. While the probe is intact, the proximity of the quencher reduces the fluorescence emitted by reporter dye. If the target sequences (wild type or the variant) are present, the probe anneals to the target sequence, down stream to one of the primers used for amplifying the DNA sequence flanking the position of the variants. For an assay two flanking PCR primers, two probes corresponding to the wild type and variant allele and labelled with two different reporter dyes and quencher were used. During extension the probe may be cleaved by the Taq-polymerase separating the reporter dye and the quencher. Three individuals were genotyped using this assay. Sample for individual I shows maximum fluorescence for the dye attached to the wild type probe, sample for individual II shows maximum fluorescence for

the dye attached to variant probe and sample for individual III exhibits equal fluorescence for both the dyes. Which of the following statement is correct ?

1. Individual I is homozygous for the variant allele.
2. Individual II is homozygous for variant allele.
3. Individual II is homozygous for wild type allele.
4. Individual III is homozygous for wild type allele.

**Ans. 21**

139. Stem cell therapies are being used in regenerative medicine like forming new adult bone, which usually does not regrow to bridge wide gaps. Successful attempts have now been made in this area because the same paracrine and endocrine factors were found to be involved in both endochondral ossification and fracture repair. Few methods to achieve the above are given below:

- A. Develop a collagen gel containing plasmids carrying the human parathyroid hormone gene and place in the gap between the ends of the broken leg.
- B. Develop a gel matrix disc containing genetically modified stem cells to secrete BMP4 and VEGF-A and implant it at the site of the wound.
- C. Make scaffolds of material that resemble normal extracellular matrix that could be molded to form the shape of a bone needed and seed them with bone marrow stem cell.
- D. Develop a collagen gel containing plasmids carrying the human bone marrow cells and place them between the ends of the bones.

Which of the above methods would you employ to develop a new functional bone in patients with severely fractured bones.

- (1) A and B      (2) A, B and C      (3) A and C      (4) C and D

**Ans. 1**

140. Cre/loxP system is used by phage PI to remove terminally redundant sequences that arise during packaging of the phage DNA. Cre-lox system can be used to create targeted deletions, insertions and inversion in genomes of transgenic animals and plants. Consider a series of genetic markers A to K. How should the Lox P sites be positioned in order that Cre recombinase can create an inversion in the EFG segment relative to ABCD and HIJK ?

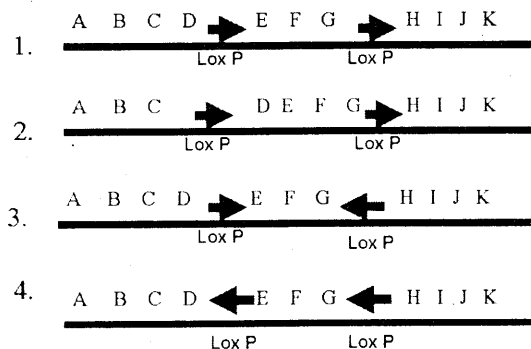

**Ans. 3**

141. Figures A and B respectively represent the dideoxy sequencing gels obtained for partial sequences from 5'-ends of a bacterial gene and its mutant (with a point mutation).

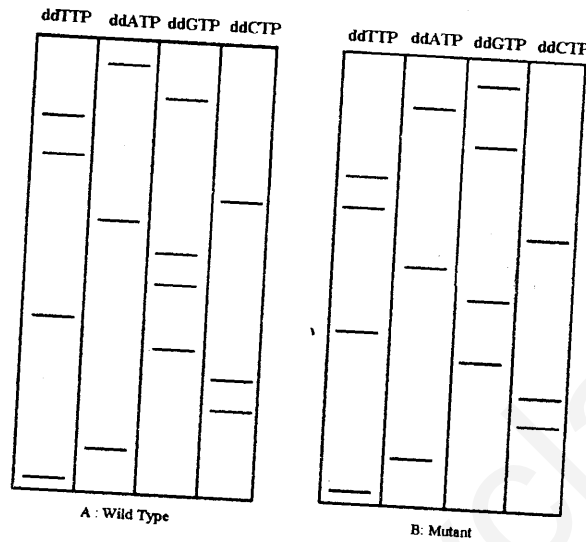

What type of mutation has occurred in the gene ?

Ans. 3

- (1) Nonsense      (2) Missense      (3) Frameshift      (4) Transversion

142. T cell proliferation *in vivo* is to be analyzed. The cells are labelled with CFSE (a fluorescent probe) and injected in CD86-deficient mice and BALB/c mice along with the required antigens. Three days later, the cells are recovered and analyzed by flow cytometry. Which one of the following is logically correct?

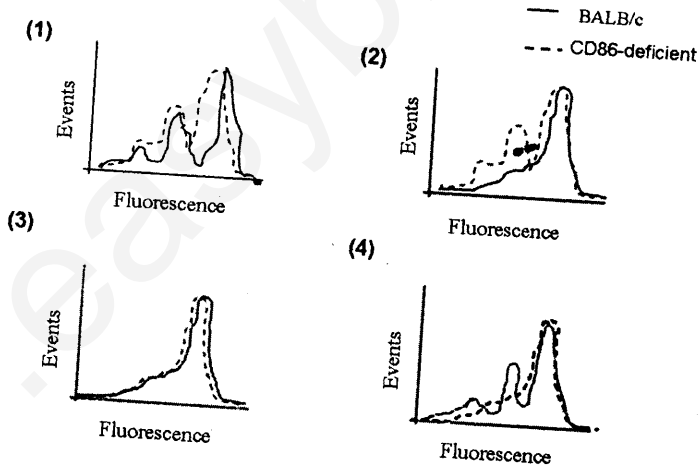

Ans. 2

143. The most important property of any microscope is its power of resolution, which is numerically equivalent to  $D$ , the minimum distance between two distinguishable objects.  $D$  depends on three parameters namely, the angular aperture,  $\alpha$ , the refractive index,  $N$ , and wavelength,  $\lambda$ , of the incident light. Below are given few possible options to increase the resolution of the microscope.

- A. Decrease the value of  $\lambda$  or increase either  $N$  or  $\alpha$  to improve resolution.
- B. Moving the objective lens closer to the specimen will decrease  $\sin \alpha$  and improve the resolution.
- C. Using a medium with high refraction index between the specimen and the objective lens to improve the resolution.
- D. Increase the wavelength of the incident light to improve the resolution.

Which of the following combination of above statements is correct?

- (1) A and C      (2) B and C      (3) A and D      (4) C and D  
*Ans. 1*

144. In an animal experiment;

- (i) Electrical stimulation of an area in the brain (A) increased a function (F) which was prevented by systemic injection of adrenergic antagonistic, prazosin.
- (ii) Injection of carbachol (cholinergic agonist) into A also increased function F which was, however, not prevented by systemic injection of adrenergic antagonistic, prazosin.

The results are likely to be due to the stimulation of

- 1. Nonadrenergic and cholinceptive neurons
- 2. Cholinergic and non-adrenoceptive neurons
- 3. adrenergic terminals in 'A'
- 4. both neurons and fibres passing through 'A'

*Ans. 4*

145. In the following statement taken from a research paper, what does  $p$  in the parenthesis stand for?

"The mean temperature of this region now is significantly higher than the one 50 years ago ( $p < 0.05$ , t-test)"

- 1. Ratio of the mean temperatures of the two time periods tested
- 2. Probability of the error of rejecting a true null hypothesis
- 3. Probability of the error of accepting a false null hypothesis
- 4. Probability of the t-test being effective in detecting significant differences in the mean annual temperatures of the two time periods

*Ans. 4*

Please visit: [www.easybiologyclass.com](http://www.easybiologyclass.com) for:

- Lecture Notes
- Biology PPTs
- Biology MCQs
- Online Mock Tests (MCQ)
- Video Tutorials
- Practical Aids
- Model Question Papers of NET, GATE, DBT, ICMR Exams
- CSIR NET Life Sciences Previous Year Question Papers
- GATE Previous Year Question Papers
- DBT BET JRF Previous Year Question Papers
- ICMR JRF Entrance Exam Resources
- Jobs Notifications
- Higher Studies in Biology / Life Sciences
- Seminar / Workshop/ Conference Notifications
- *And many more....*



Please subscribe our **youtube** channel: **easybiologyclass**  
<https://www.youtube.com/user/easybiologyclass/videos>



You can access more PDFs & PPTs from our **Slideshare** account  
<http://www.slideshare.net/EasyBiologyClassEBC/>



Our sister concern: [www.angiospermtaxonomy.com](http://www.angiospermtaxonomy.com)